



H

CLEARFIRE®

**HIGH-EFFICIENCY, COMMERCIAL STEAM BOILER
10-60 HP**

High-Efficiency, Low Emission Steam Boiler in a Compact Footprint

The ClearFire®-H compact, gas-fired horizontal boiler is designed specifically for the requirements of the commercial market and is available in sizes ranging from 10-60 horsepower for 15# or 150# psig steam pressure.

ClearFire-H

10-60 HP

Features

Maximum fuel savings with ALUFER® firetubes, full burner modulation and high-turndown via variable speed blower

High efficiency, up to 85% reducing greenhouse gas emissions

Easily tuned, zero-governor, premix burner

Reliable operation, no dampers or linkages

Advanced combustion design eliminates need for flue gas recirculation and provides low emissions (<20 ppm NOx and <10 ppm CO)

ModBus (RS485) communications

Ultra-quiet operation less than 70 dBA

Reduced electrical energy consumption with single phase power -115V

Direct spark ignition

Low gas supply pressure (less than 14" w.c.)

cULus Listed (Natural Gas)

Controls are ASME CSD-1 Compliant

15# & 150# designs deliver superior steam quality



The ClearFire-H Advantage

- 1 Operating and high-limit controls
- 2 Single-point connection for electrical and controls
- 3 Surface blowoff
- 4 Modulating low NOx burner assembly for maximum operating
- 5 Single-pass firetube design, thermal shock resistant
- 6 Fiber mesh burner designed to premix air and fuel for optimal combustion
- 7 CSD-1, XL GAP gas train
- 8 Small stack outlet
- 9 Steam outlet
- 10 Large steam volume, better steam quality
- 11 Patented ALUFER[®] tubes for increased heat transfer
- 12 Handhole(s) for water side inspection

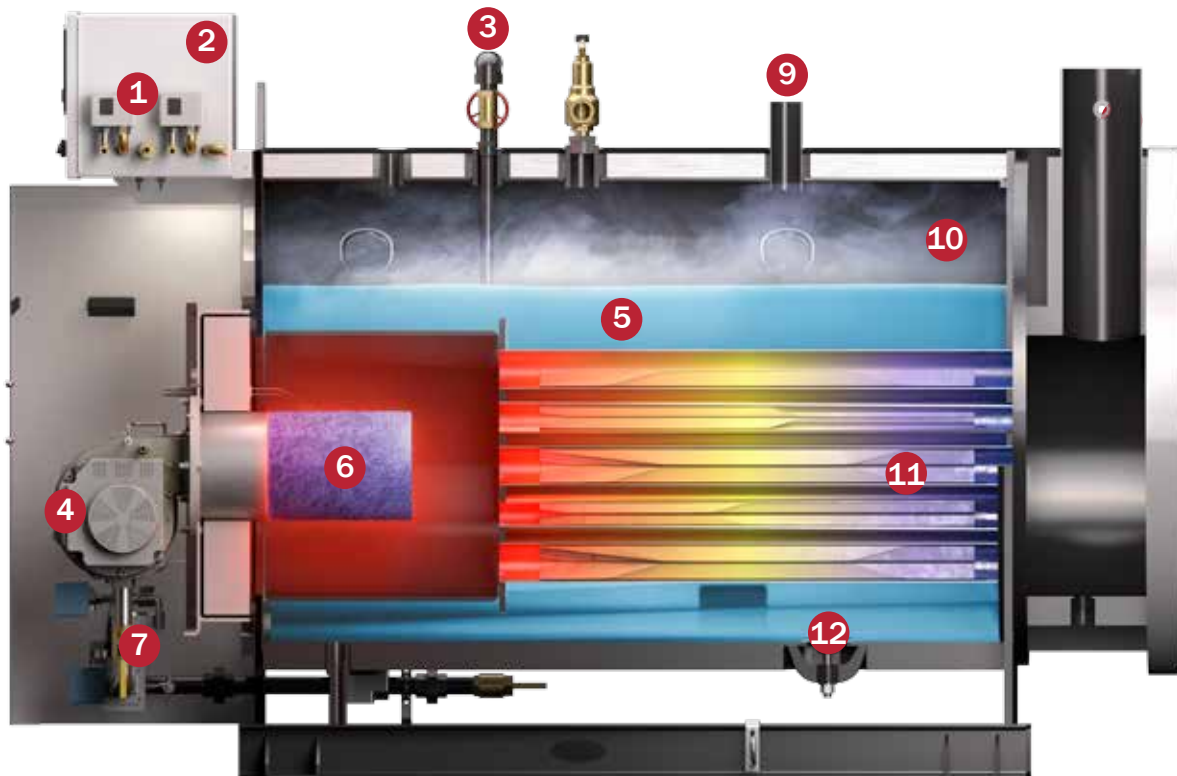

Optimize Your Steam System

Patented ALUFER® Heat Transfer Technology



Patented ALUFER Tubes

The internationally patented ALUFER tube is the technology behind the advanced heat transfer design. The tube is constructed from an inner (fireside) aluminum alloy finned surface, die-fitted within an outer steel tube, providing exceptional heat exchange characteristics.

- Thermal conductivity of the ALUFER insert is significantly greater than that of carbon steel.
- Internal finned surface of the ALUFER tube enlarges the heat exchange surface area three-fold.
- Inner surface of the tube is divided into 10 flow channels to enhance turbulence and maximize heat transfer.

Heat Exchanger And Burner

The ClearFire®-H boiler has a high-quality, steel combustion chamber with ALUFER firetubes. The single-pass horizontal arrangement ensures maximum heat exchanger effectiveness and superior steam quality. The high-turndown modulating burner minimizes short cycling and allows the boiler to operate at peak efficiency.

Thermal Shock Resistance

The single-pass arrangement is designed to inherently minimize thermal stress in the heat exchanger.

ClearFire-H Options

- Blowdown & feedwater valve assemblies
- Surface blow-off controls
- Chemical feed tank
- Integral feedwater system
- Feedwater economizer
- High-pressure regulator
- Reusable air filter
- Sealed combustion provision for reduced make-up air requirement
- Lead/lag control for multiple boiler systems
- Pre-fabricated exhaust solutions
- Building EMS communication interface solutions

Premix Modulating Burner Operation

The premix burner controls automatically adjust the air and gas mixture to the correct proportions before it enters the burner. A symmetrical, 360° even-temperature heat output is achieved from the burner, providing clean combustion with low NOx emissions. Turndown is up to 5:1 with emissions of less than 20 ppm.

Burner Gas Train

Standard components meet the requirements of cULus, ASME CSD-1, XL-GAP and FM.

- Low gas pressure manual reset
- High gas pressure manual reset
- CSD-1 test cocks
- Manual test valve
- Dual safety shutoff valve
- Gas pressure regulator

Gas train is factory piped and wired on the burner.

Boiler Trim and Controls

Boiler trim is in accordance with cULus and ASME CSD-1.

- High limit pressure control
— manual reset
- Operating limit pressure control
- Combustion air proving switch
- Primary LWCO and pump control
- Manual reset ALWCO
- ASME safety relief valve set (15 psig or 150 psig)

Intelligent Integrated Controls

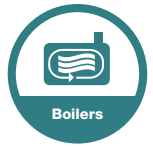

The Cleaver-Brooks Falcon is a proven boiler/burner management control that provides an intuitive operator interface featuring integrated burner sequencing, trending, flame safety, modulation, alarms, lockout and much more, ensuring your boiler system operates at peak efficiency, while providing necessary safety and reliability.

The Cleaver-Brooks Falcon control with integrated lead/lag optimizes the boiler room's operational efficiency while delivering precise temperature control to meet heating demands. The Cleaver-Brooks Falcon can communicate with your building's Energy Management System (EMS), which helps maximize overall system efficiency.



User-friendly Controls

- Touch screen graphics
- PID set point control (single boiler and lead lag)
- Configurable lead lag control up to eight boilers
- Comprehensive diagnostics/fault history
- Combustion air/draft control interlock
- Night set back
- Hot standby
- ModBus (RS485) Communications



The ClearFire-H is the ideal boiler for both heating and process steam applications

The Falcon lead/lag control is uniquely capable of optimizing the ClearFire-H's combustion and thermal performance characteristics to sequence and modulate ClearFire-H boilers to maximize steam plant efficiency. The Cleaver-Brooks Falcon lead/lag control uses the common base load firing rate method to sequence and modulate a multiple-boiler system. This approach optimizes the boilers' operating efficiency while minimizing energy-wasting short cycling. The elimination of short cycling minimizes purge and standby losses, while extending the life and reliability of your boiler system.

Single Source Skid Package Solutions

Looking for a turnkey steam solution? Cleaver-Brooks offers standard and complete steam boiler system skid mounted packages in gas and propane fuels. The package includes the steam boiler, feed system and blowdown separator with optional chemical feed system and water softener. This complete package saves you time installing the system as all that is required is a single-power, gas, steam and water connection.

Features

- Single-source responsibility
- Plug and Play, reduced installation cost
- Standard skid solutions to meet your needs
- Eliminate field piping and wiring errors



Maximize Efficiency to 87% with an Economizer

The ECF ClearFire[®] economizer is a stainless steel coil tube arrangement using extended heating surface fins to maximize heat transfer. Flue gas from the boiler passes over the coiled tube, which conveys incoming feed water. Feed water preheated in this fashion reduces the need for a steam feed water heater, resulting in efficiencies of up to 87% in non-condensing applications.

Integral CFH Economizer

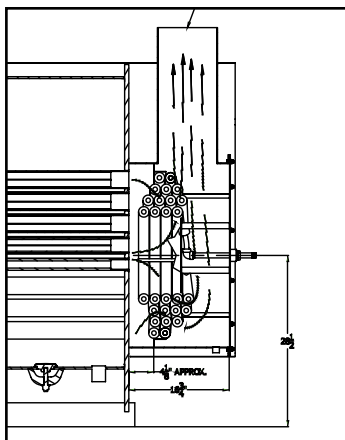

External Economizer



ClearFire-H Boiler Dimensions and Ratings

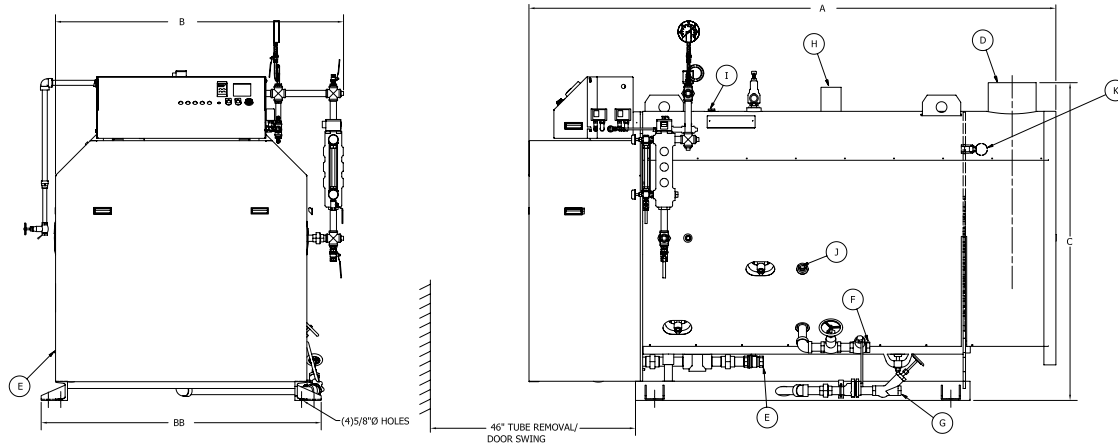
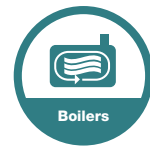

| Boiler Horsepower | 10 | 15 | 20 | 25 | 30 | 40 | 50 | 60 |
|---|-------|-------|-------|-------|-------|-------|-------|-------|
| Dimensions – inches | | | | | | | | |
| Overall Length (A) | 86 | 86 | 87 | 87 | 92 | 104 | 110 | 110 |
| Overall Width (B) | 44 | 44 | 47 | 47 | 55.5 | 55.5 | 60.5 | 60.5 |
| Width (BB) minus water column and blowdown | 38 | 38 | 41.5 | 41.5 | 49 | 49 | 55 | 55 |
| Overall Height (C) | 54 | 54 | 57 | 57 | 66 | 66 | 68 | 68 |
| Connections - inches | | | | | | | | |
| Stack Nominal OD (D) | 6 | 6 | 6 | 6 | 8 | 8 | 10 | 10 |
| Gas Connection (E) | 1 | 1 | 1 | 1 | 1 1/4 | 1 1/4 | 1 1/2 | 1 1/2 |
| Feed Water (F) | 1 | 1 | 1 | 1 | 1 | 1 | 1 1/4 | 1 1/4 |
| Bottom Blowdown (G) | 1 | 1 | 1 | 1 | 1 | 1 | 1 1/4 | 1 1/4 |
| Steam Outlet (H) 15# ST. | 4 | 4 | 4 | 4 | 4 | 6 | 6 | 6 |
| Steam Outlet (H) 150# ST. | 1 1/2 | 1 1/2 | 1 1/2 | 1 1/2 | 2 | 2 | 3 | 3 |
| Surface Blowoff (I) | 1 1/4 | 1 1/4 | 1 1/4 | 1 1/4 | 1 1/4 | 1 1/4 | 1 1/4 | 1 1/4 |
| Chemical Feed (J) | 1 | 1 | 1 | 1 | 1 | 1 | 1 | 1 |
| Overflow (K) | 1 | 1 | 1 | 1 | 1 | 1 | 1 | 1 |
| Steam Boiler Weights in lbs | | | | | | | | |
| Normal Water Weight - 15# | 920 | 920 | 1,150 | 1,150 | 1,710 | 1,980 | 2,510 | 2,510 |
| Normal Water Weight - 150# | 1,010 | 1,010 | 1,250 | 1,250 | 1,850 | 2,150 | 2,700 | 2,700 |
| Approx Shipping Weight | 2,450 | 2,450 | 2,750 | 2,750 | 3,400 | 3,700 | 5,200 | 5,200 |
| Power Requirements (115VAC, 60 Hz, single phase) | | | | | | | | |
| Blower Motor Size (Watts)* | 335 | 335 | 335 | 335 | 335 | 750 | 1,200 | 1,200 |
| Ratings | | | | | | | | |
| Rated Capacity–Steam (lbs-steam/hr from 212°F) | 345 | 518 | 690 | 863 | 1,035 | 1,380 | 1,725 | 2,070 |
| Efficiency % | 86.2 | 85.2 | 85.6 | 85.1 | 85.9 | 85.8 | 86.2 | 85.8 |
| Output (1,000 BTU/hr) | 339 | 503 | 674 | 838 | 1,015 | 1,351 | 1,697 | 2,027 |
| Input (1,000 BTU/hr) | 394 | 591 | 788 | 984 | 1,181 | 1,575 | 1,969 | 2,363 |
| Fireside Heating Surface (sq.ft.) | 122 | 122 | 191 | 191 | 310 | 381 | 573 | 573 |
| Turndown/Modulating Firing Range | 4:1 | 4:1 | 4:1 | 4:1 | 4:1 | 5:1 | 5:1 | 5:1 |

Notes:

*For altitudes above 1,500 ft., contact local Cleaver-Brooks authorized representative for verification of boiler and blower motor size.

**All Ratings from 0 psig and at 212°



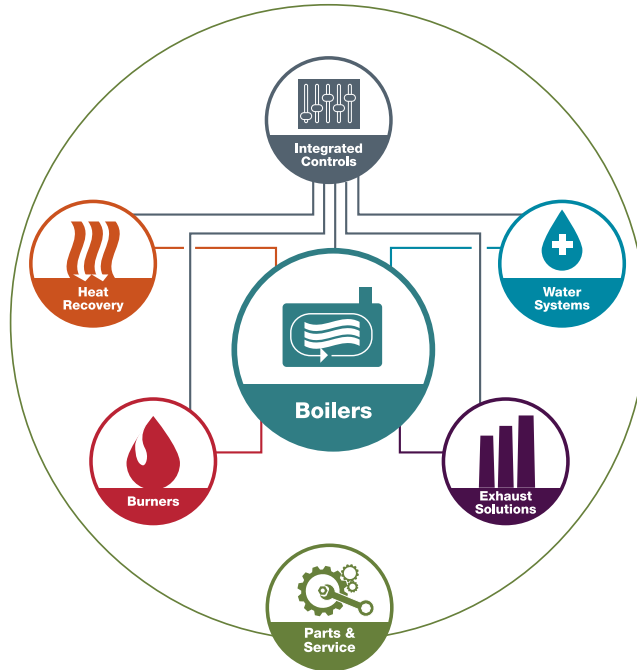

Total Integration goes far beyond boilers.

For more than 80 years, Cleaver-Brooks has built a reputation for innovation in the boiler solutions industry. We remain committed to introducing technology and products that enable a more energy-efficient and environmentally friendly generation of steam and hot water.

When you come to us for a boiler solution, you can know that each element is created to the highest standards and all will work together seamlessly to give you a highly efficient and reliable solution for protecting your boiler system. To learn more, please call or visit us online.



Packaged Boiler Systems
221 Law Street • Thomasville, GA 31792 USA
800-250-5883 • info@cleaverbrooks.com
cleaverbrooks.com